

Year 10 Engineering Knowledge Organizer Booklet

Student Name: _____

Class: _____ Target Grade: _____

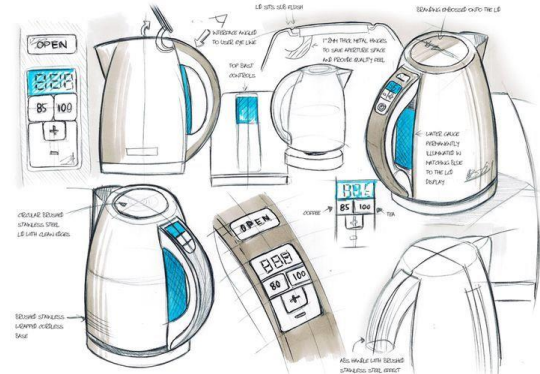

Study Tips:

- Use your **QLA's** – check your old assessments against the QLA to find “weak areas” so you know you’re studying something useful
- Check your **Feedback & Marking Grid** – look for feedback in these grids to find areas which need to be improved, comparing the grid to your work
- Use your **knowledge organisers** – read through a knowledge organiser each night, and re-write aspects of it to help you memorise information
- Find **exemplar copies** of answers – an exemplar copy should show you what a perfect, full mark answer looks like and help you understand what you need to do to pick up marks
- Make **flash cards** – write a question on one side of a piece of card, and the answer on the other, and use these to test yourself. If you quiz yourself like this, it won't be long before you begin to remember the answer
- **Read, cover, write, check** – test your memory while studying by reading some key notes. Then cover the notes, and try to re-write what you have just read, from memory. Once finished, compare what you have written with the original notes and see how close you got. This works great!
- Return to **old assessments** and fill in gaps where you lost marks – if you lost marks on a paper, go back and use your notes to help you write your own exemplar answers in green pen – this will show you what topics you need to improve and how much info was missing on your first try.
- **Practice** – some things just need practice to get used with how to do it, so aim to get through as many practice questions/drawings/maths problems or past papers as you can so nothing surprises you in the exam.
- **Ask for help** if you need. Every teacher and no doubt your friends or parents will be happy to help you ask, instead of getting stuck & frustrated

In the exam – answering questions:

- **Reading the question** – read each question carefully, then read it again. Think about the *context*, and look for clues about *how it should be answered* – what key words do you see? Does it mention underlining, sketching, stating or explaining your answer?
- **Count the marks** – 1mk questions will be a quick response, but 2mks+ will require more development & explanation to win you full marks
- **Use your answer space** – check how much space is designated for the answer – why do you think they put 4 lines in the answer space? Expect small marks from small answers
- **Watch your time** – don't spend half the exam on one question – plan how much time you will spend on each answer based on the amount of marks available. But use your time too – if you have 90mins for the test, then you need to make use of every minute to gain points.
- **Be as clear as you can** – the examiner doesn't know you, so can't assume you know anything you haven't clarified. Always explain your point to show off your understanding
- **Re-read your answer** – seems obvious, but double check your answer makes sense when it is read, because the examiner will not be able to read your mind.

Types of exam questions:

- ✓ **Look for key phrases in the question.** How is it phrased? Explain/describe/discuss/compare, etc. – these key words show you need to *develop your answer with a few sentences*. State/Give/underline, etc. – these answers should be quick 1 or 2 word responses
- ✓ **Sketching questions** – you will be marked on how well you communicate your point, so make the sketch relevant. Always add labelling to the sketch and use notes along with it to discuss and explain the contents & the idea you are communicating
- ✓ **Maths questions** – you may use a calculator, but you should still always show your working out – jot down each step & what equations you have used, then just use the calculator for the maths – this way you will gain more marks, even if your answer is off

Example Question:

Explain why the adjustable drip tray of a coffee machine has been manufactured from stainless steel. [2mks]

Note the word “**Explain**” – you will need to develop and clarify your point for 2 marks.

Example answers:

0mk answer:

“Because it's strong”

The problem: no explanation, too short and unclear – this looks like you have no idea what to write so you don't understand what you're saying

1mk answer:

“Because it won't rust”

Links to the question better, and shows you have thought about the context, but *lacks explanation* – why won't it rust? Show the reader it's not a lucky guess and aim to clearly link to the scenario

2mk answer:

“Stainless steel is used because it is an alloy containing chrome so it will not rust if exposed to moisture on the coffee machine”

Links to the context of the question better, and shows good understanding as it explains why the stainless steel won't rust over time.

Knowledge Organizer – BTEC Eng. – Material Properties:

- Material properties are how we describe the characteristics of a material by observing how they react to or cope with particular circumstances or stimuli. These could involve resistance to heat, light, electricity, chemicals, or **forces** for example and help us make clear comparisons between materials so that we can make better decisions about what processes, tools or applications would be best suited to that material.

Compressive Strength:

This is the measure of a material's ability to withstand a **squashing force**, where pressure is applied from opposite directions. Low compressive strength will mean the material will deform under the force, but high compressive strength will mean it will be more likely to take the pressure without changing shape.



Tensile Strength:

Tensile Strength is a material's ability to resist being stretched when forces act upon it in opposite directions, trying to pull apart/stretch or elongate the material.

Poor tensile strength will lead to stretching where high tensile strength means the material will hold the pressure and not stretch or break.



Rigidity:

This is a material's ability to resist a bending force. A bending force will try to change the shape of the material by putting one side of the material under tension and the other under compression through opposing forces and resistances.

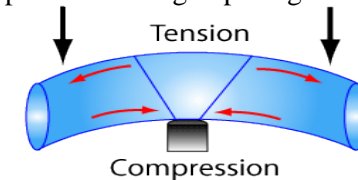

Shear Strength:

This is the measure of a material's ability to resist opposing forces which act side by side; similar to how a scissors works. Aluminium has low shear strength compared to other metals, so it is easy to cut it on the guillotine. Low shear strength means the material can be essentially torn apart at the point where the acting force changes direction.

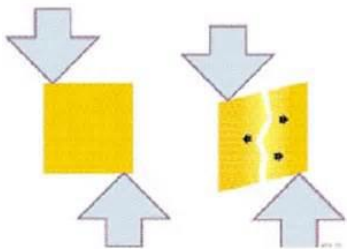

Impact Strength:

This is the measure of how well a material can resist impact before failing or breaking; in other words, how much shock it can absorb. Impact stress exposes the material to sudden, brief and high levels of forces like tension and compression, rather than over an extended period of time – in this case its strength would be referred to as toughness.

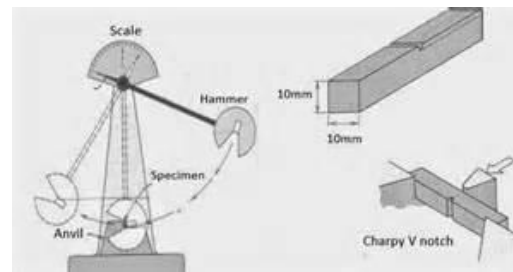

Torsion:

Torsion is a force that tries to deform a material with a twisting force. Good torsion resistance is very important in engineering for the strength of engine parts, helping ensure nuts and bolts are tightened enough, and in transferring force through screwdrivers, etc. Poor torsion resistance could lead to fatigue and twisting or failure of a part

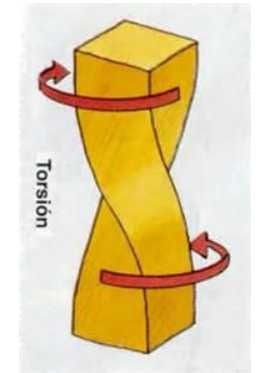

Hardness:

Hardness is the measure of a material's ability to **resist scratching or indentation** from a force that has been applied (also known as abrasion). The materials used in files and grinders have to be very hard to ensure they are harder than the material they are being used on and so wear down slower.

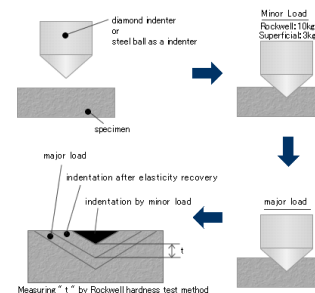

Knowledge Organizer – BTEC Eng. – Material Properties 2:

- Material properties are how we describe the characteristics of a material by observing how they react to or cope with particular circumstances or stimuli. These could involve resistance to heat, light, electricity, chemicals, or **forces** for example and help us better understand how it will perform in different situations

Elasticity:

This is a material's ability to return to its original shape once a force which was deforming it in some way has been removed. A great example of this is how an elastic band snaps back to its original shape when you stop stretching it.



Conductivity/Insulation:

Conductivity is the measure of how well the material can transfer either electrical current, or heat.

Insulation is the measure of how well the material can slow or stop the transfer of heat or electrical current across it.

For example, copper is a great electrical conductor, while the plastic flex around the wire is a good insulator, preventing you from getting a shock.

Corrosion resistance:

This is how well a material can resist becoming degraded by a chemical reaction. Any ferrous metals will rust over time, but other materials may still corrode or oxidize just in a different way.



Transparency/Opacity:

This is the measure of how much light can pass through that material.

A transparent material will easily allow light to pass through it.

An Opaque material will prevent light from passing through it.

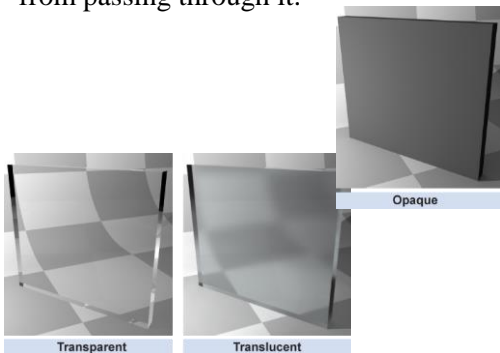

Malleability:

This is the measure of a material's ability to change shape without breaking when it is put under some sort of compressive stress. This is often used with a stamping, or hammering action.

Many metals and plastics will become more malleable when they are heated, so when you see a blacksmith forging some red hot steel on an anvil, they are taking advantage of the fact that the hot steel is more malleable than cold, and is then easier to shape.



Ductility:

This is a material's ability to deform under tensile stress without breaking. A ductile material will be able to be drawn out into thinner and thinner strips as it is stretched, without snapping.

Copper is very ductile, and this is why it gets used for wires.

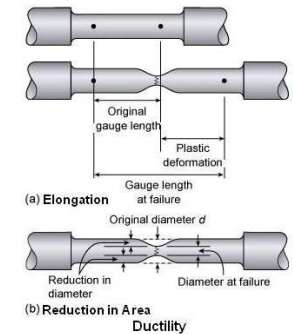

Magnetism:

Another property a material could have is magnetism. Generally only ferrous metals can be magnetised, but it can be a very useful property if utilised right.

Iron, Nickel and cobalt are among the only metals which can be magnetised.



Year 10 Knowledge Organizer - Drilling

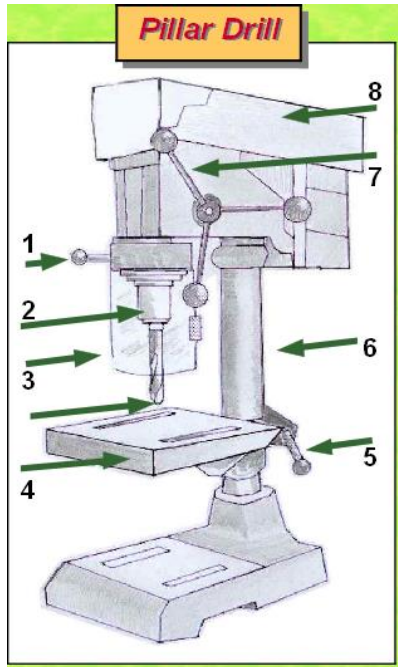

Machine Parts List:

- 1) Spindle housing
- 2) Drill chuck
- 3) Chuck guard
- 4) Machine table
- 5) Locking lever for machine table
- 6) pillar/column
- 7) Lowering lever/handle
- 8) Drive belt housing

Advantages of using the Pillar Drill:

- Safer drilling as the material is secured on the table, and the drill bit is more controlled
- More accurate, as it will always drill perfectly square to the material, unless we set the table at an angle
- The drill chuck is in a fixed location, meaning the drill bit can't "skate" along the work surface and cause scratches – a common problem with hand drills
- It is easy to accurately set a required depth for drilling blind holes
- Easier to control the "feed rate" (amount of force behind the drill bit) by using the lowering lever which can help produce cleaner cuts.

Drill Bit Types List:



Hole types List:

- a. blind hole – this type of hole goes partly through the material, but stops short of bursting through the back surface
- b. Through hole – a hole that is drilled all the way through the material
- c. A hole whose wall slopes inwards as it gets deeper
- d. Counter bored hole - a hole with cut with an increased diameter at its opening, designed to allow the head of a bolt sit flush with, or below the surface of the material
- e. Counter sunk hole – a hole which has a taper cut at its opening, to allow a screw head (csk) to sit flush with the surface of the material



When we need to change the drill bit in the chuck, we can lock and unlock the chuck using the **chuck key** shown. You should find this stored with the different drill bits at each machine.

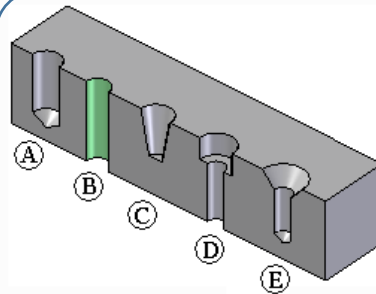

- A. Blind hole
- B. Through hole
- C. Tapered hole
- D. Counter bored hole
- E. Counter sunk hole

Engineering Knowledge Organiser – The Centre Lathe

The Centre Lathe

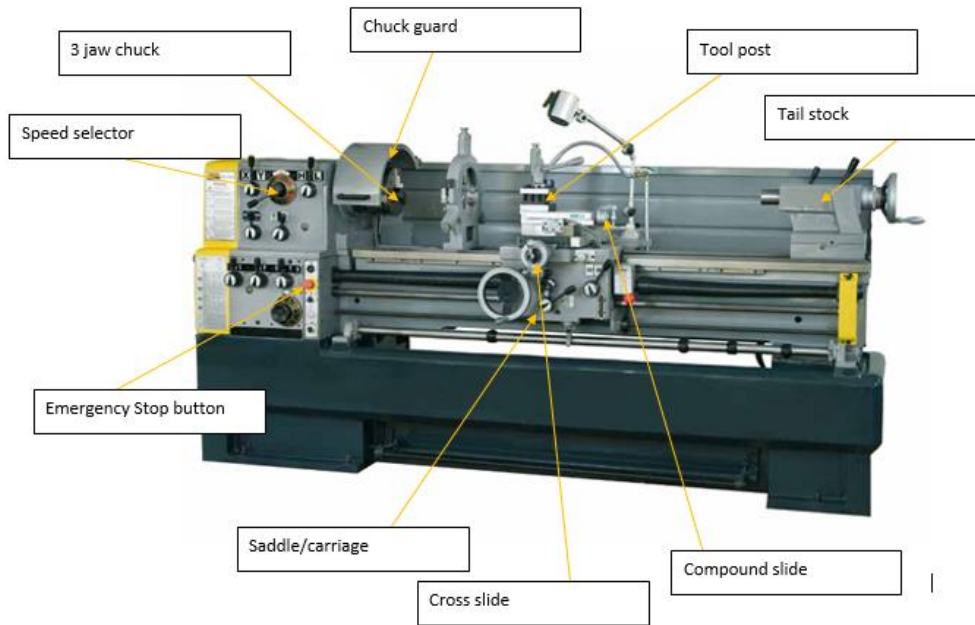

- The 3 jaw chuck holds the material you are working on as it spins
- The speed selector determines how quickly the material you are working on spins around
- The chuck guard helps prevent the user from coming into contact with the spinning chuck, can help prevent swarf being dangerously ejected from the lathe, and will usually cut power to the machine when lifted to prevent the lathe from being turned on with the chuck key still in place.
- Emergency stop button is to stop the machine quickly in the event of an emergency
- The cross slide controls the movement of the cutting tool in a direction perpendicular to the axis of rotation
- The compound slide allows us to control the position of the cutting tool when making tapered cuts
- The tail stock is used mainly for holding long pieces in place by using a dead centre to grip the loose end, and can also be used for drilling into the end of a piece if work if a chuck attachment is added.
- The tool post holds the cutting tool in place as you work.



Screw-cutting involves cutting helices into the work piece at a required angle, depth and pitch to form screw threads

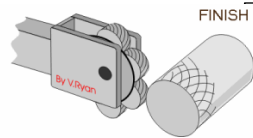

Knurling cuts a textured pattern into the surface of material to provide grip on the piece.

- Metal is cut on a Lathe by slowly feeding a **cutting tool** against the material.
- The **cutting tool** is made from hardened steel or from carbide tipped tools and is held rigidly in the **tool post**.

Processes on the Centre Lathe:

Facing Off

In facing off, the tool is moved at *right angles* to the axis of rotation of the work by means of the cross slide.

Flat surfaces are produced and this is the process used to face work and finish shoulders

This process is only done on the end of the rotating piece of the material as shown.

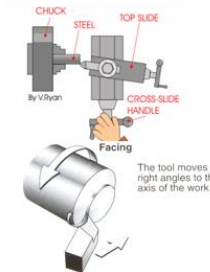

Parallel Turning:



The tool moves parallel to the axis of the work.

In parallel turning, the tool moves *parallel* to the axis of rotation of the work and cylindrical forms are produced.

This technique is used when we want to clean up the sides of a piece, or reduce the diameter of the piece

As the cutting tool moves along the side of the rotating material, it shaves off the outer layer.



Drilling:

Centre drilling on the lathe involves inserting a 3 jaw chuck attachment into the tailstock of the lathe.

Winding the wheel at the back of the tailstock will slowly plunge the drill bit into the end of the rotating material.

As the material is spinning in the chuck, the drill bit does not need to spin.



Boring uses a tool in the tool post to ream holes, increasing their diameter with high accuracy.

Parting off

Parting off is like the opposite of parallel turning in that the cutting tool runs perpendicular to the axis of rotation rather than parallel.

By doing this, we dig the parting off tool into the side of the rotating material until we reach the centre, causing a part of the material to be cut off the end of our workpiece.



Figure 1: the collet chuck allows material to be gripped without damaging the outside surface.



A Mandrel is used to hold material whilst being turned, by being inserted and applying outwards pressure on hollowed parts, meaning their entire outside surface can be worked on

Knowledge Organizer – WJEC Eng. – Lathe Processes:

Important steps when setting up the lathe:

- Ensure the correct tool is installed in the tool post
- Check tool height in relation to the workpiece – the cutting edge should be perfectly level with the centre of rotation
- Set the correct RPM for the material type, and stock diameter you are working on.
- Ensure material is secured appropriately for the job; 3/4 jaw chuck, fixed or travelling steadies, between centres, etc
- Check if coolant is needed and ensure the reservoir is filled and flowing well before starting
- Check all necessary safety measures; locate emergency stops, wear correct PPE, ensure chuck guard is in place, etc.

Facing off – skimming material from the end of our work piece whilst it turns, to give a clean, flat, square surface. **Finishing cuts** which remove only the smallest amount of material will give the best finish.

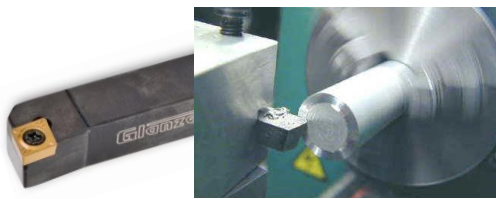

Parallel Turning – skimming material from the side of our work piece parallel to the **axis** of rotation (central line around which the material is spinning), to accurately reduce the diameter/overall width of the cylinder to a consistent size.

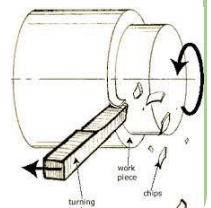
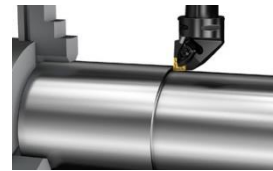

Parting off – plunging a cutting bit into the side of our material, until the tip reaches the centre and cuts off a section of the bar. A cut that only goes part of the way in will be called an undercut, making a lip in the stock.



Taper Turning and chamfering – gradually reducing the diameter over a length of the bar, creating a sloped side. Chamfering will involve creating a small bevel with a steeper angle at an end or shoulder on the workpiece.

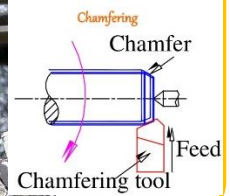
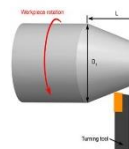

Profile Turning – using a custom-made cutting tool shaped to match the intended final shape/profile of the part. This has the advantage of combining various processes in one pass as the shaped bit gets plunged into the material, saving time changing tools.

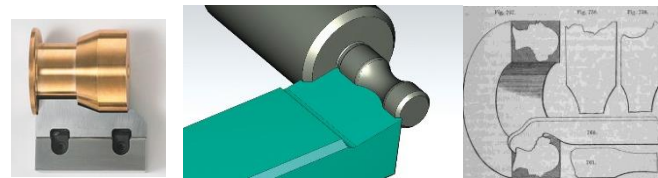

Knurling – The knurling tool gets pressed into the outer surface of the material whilst it turns, causing its teeth to dig into the material and cut a texture which can be useful for providing grip, like on the handle of a dumbbell, thumb screw or socket wrench.



Boring – This process is similar to parallel turning, but it is completed on the inside of the part, allowing for a drilled hole to be very accurately increased in size, to a larger diameter than we could achieve with a drill bit, and leaving a clean inner surface.

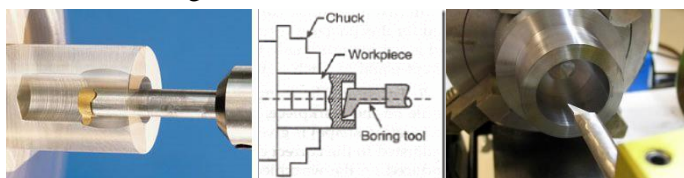

Threading – The threading tool will cut a v-shaped gouge into the side of the material to create screw threads. For this to work, the cutting bit must travel along the side of the material at the right speed to match the rotation speed in order to give the correct pitch of thread.

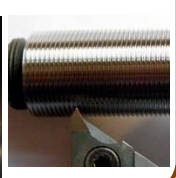
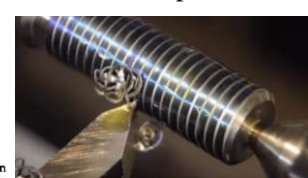
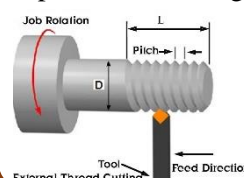

Knowledge Organizer - BTEC Eng. Unit 1 -

Manufacturing Processes:

Laminating:

This is the process of gluing together multiple layers of material (whether the same or varied materials)

Benefits can include increased strength, benefits from compositing materials together, making curved sections of material or improved appearances where a surface “skin” has been laminated to the material to add durability or make it look good.

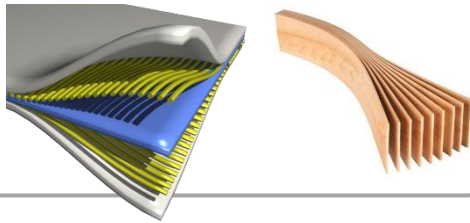

Injection moulding:

Pellets of raw material (metal/plastic) are fed into a heated tube containing an Archimedes screw, which forces them towards a nozzle. Once enough melted material has built up, it will inject this liquid into a mould under high pressure (similar to die casting) before starting again. It is a **very automated** process – very little manual labour.

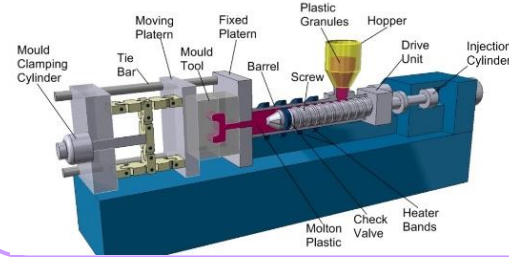

Milling:

A process whereby a spinning cutter head pares away waste material, usually in metal parts. Milling can involve drilling operations as well as cutting slots, shoulders or rebates into metals and can perform very complex cuts if broken into steps.

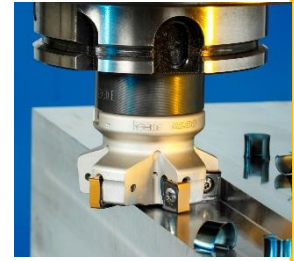

Shearing:

A method of cutting sheet metal or other thin sections by using shear force to tear the material apart. It is fast, accurate and leaves an edge that requires little to no clean up.

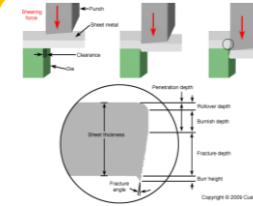

Sintering:

This involves heating a compacted material like a powder to the point that the particles fuse together and form a solid, but without reaching a critical temperature where they melt

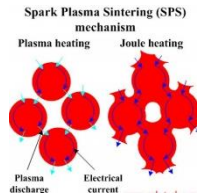

Blow Moulding:

Used to make hollow plastic parts, by taking a “blank” and heating the material until it is soft and pliable. This is then suspended in a mould, and inflated with hot air, so that the plastic expands and presses against the inner surface of the mould before cooling in shape. Heavily automated process, good for mass production – plastic bottles are made this way.

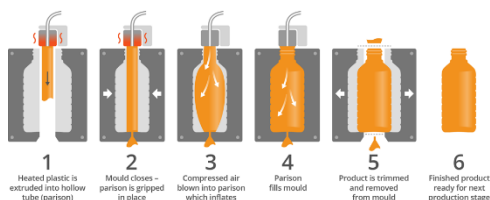

Extrusion:

Metal or plastic pellets are fed into a heated tube, and melted as they are forced along by an Archimedes screw. Rather than building up waiting to be ejected like in injection moulding, this melted material is **forced through a nozzle (die) with the required profile at a constant feed rate**, producing long profiled lengths. PVC pipes are a product of this process.

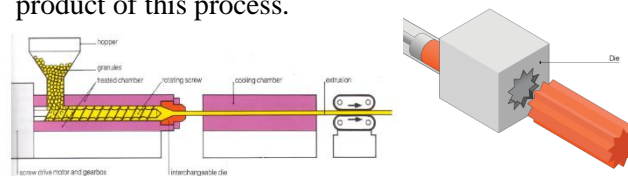

Vacuum forming:

This involves heating a thin sheet of plastic under an element, similar to a grill. Once it becomes very softened and pliable, a vacuum is created under the sheet, which sucks it down and around a template in the shape you want the plastic to form to. Yoghurt pots are made this way.

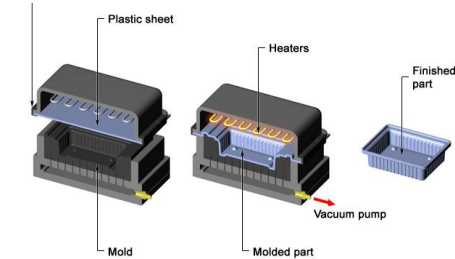

Knowledge Organizer – BTEC Eng. Unit 1 – Casting Types:

Casting

The casting process basically involves pouring molten metal or plastic into a mould patterned to look like the part to be manufactured, allowing it to cool, and removing the metal from the mould.

Types of casting:

- Sand casting
- Semi- permanent and permanent mould casting
- Investment casting
- Die casting



Investment casting

Used for parts that require **close dimensional tolerances and complex shapes** such as compressor wheels for automotive turbochargers, as it can produce casts with exceptional surface finishes.

- Usually a “master version” of the shape needed will be duplicated in wax etc. This duplicate can be encased in a seamless mould which gets emptied of the wax. Once the molten metal has set in the mould, the mould will be broken or dissolved off, leaving a highly accurate copy of the



Powder Metallurgy:

This is a modern way of producing metal part to **exact sizes leaving very smooth finished surfaces** by blending elements or **metal powders** together.

The process of powder metallurgy includes **blending, mixing, pressing and sintering**.

In this process, the mixture of required metal powders get compressed in a mould to the desired shape, before being heated (the sintering process) to help bond its particles together and set in that shape.

Binding agents might be used to help in this process.



Sand Casting:

Usually used for **large parts** where **dimensional accuracy is not as important** as other features such as a manhole cover.

- Sand is compacted around a template of the required shape, this gets split into halves, and the compacted sand becomes the mould for the molten metal to be poured into.

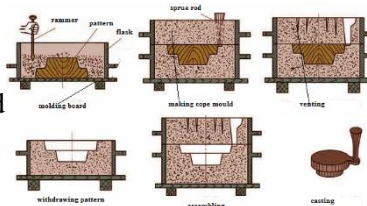

Semi- permanent and permanent mould casting

Used for products that require use with **water pressure** and in larger quantities than sand casting as tooling costs are high e.g. pressure valves.

- In this case the moulds will be reusable multiple times, and will usually be made of metal.

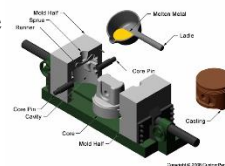

Die Casting:

This casting process is used for large quantities of the same product, with high accuracy. The Die is a 2-part mould into which the molten material gets injected. Once it has set, the 2 parts of the die can separate to release the cast shape, before being closed to start the process again.

- Alloy wheels are often produced using Die casting.

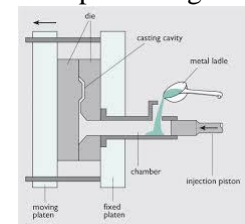

Knowledge Organizer – WJEC ENG

CNC Machines & Robots

CNC Machines:

“Computer Numerically Controlled” machines, can perform manufacturing operations based on an input from a computer program which tells the machine needs to cut/add material, and specify a path for this process.

- They essentially “print” a product or part from a computer design file with great accuracy, so will usually be used for different jobs each time but can be used for repeat tasks very well too.
- Some examples of CNC machines include:
 - CNC routers, Laser Cutters and 3D Printers, CNC milling machines

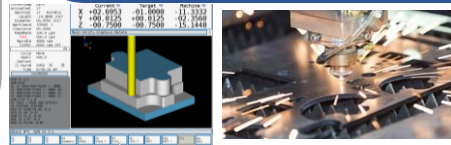

Production has changed a lot thanks to improving technology, making it more achievable than ever to make complex and functional designs. Some advances in technology which have helped engineering and production make leaps forwards in recent decades include:

- ▶ Improvements in computer hardware and software streamlining the design process
- ▶ New advanced machinery which can interact with computers and make production more predictable
- ▶ New materials technologies providing more capable materials to complete specific jobs which were unachievable before
- ▶ More precise production and nano-technology, allowing more complicated designs
- ▶ Production/performance simulations to test an idea before producing it

Robotics:

Robotics in production refers to computerised machines which have been built and programmed to carry out specific operations, some more technical and advanced than others. In the case of robotics, the machine will be programmed to perform a specific job, or combination of jobs, and will be tied to this practice in its use.

- Robots may be reprogrammed and repurposed, it will usually have been purpose built for optimal performance in carrying out a the same task over and over.
- Many robots in industrial production may involve accurate assembly of parts, welding operations, lifting heavy or dangerous objects, working in environments where there would be risks to human health, and for consistent performance, for example in spray painting to a high standard.

Advantages:

- CNC Machines can operate to a very high degree of accuracy
- They can complete monotonous, repetitive processes without getting bored or tired – once they are set up right, they eliminate problems associated with human error
- They can complete jobs much faster than hand production techniques
- They can work in environments which would not be suitable or safe for people to be in for long periods of time.
- Similarly, they can handle materials which a person could not – ie: very heavy/hot/radioactive substances
- They can boost productivity of a company massively by allowing one person to supervise several simultaneously running machines.
- They can produce very complex shapes with a very high degree of consistency
- They can help earn boost profits dramatically once set up and initial costs/training has been dealt with.
- They can save money in the long run as they can out perform human workers, and can run 24/7
- Excellent for rapid prototyping to help produce samples to help testing out new ideas or proving a concept.

Disadvantages:

- These machines are often specialised, and can be very expensive to buy and set up
- Sometimes they might come with software that might become dated, and will need reprogramming to run efficiently with new production techniques – they are not intuitive or adaptive like people
- They will need regular servicing to ensure they are running at peak performance – this will cost money each time and interrupt production
- There is a shift in training and skills, meaning some deeper understanding of processes may be lost, and some skills and crafts can get forgotten
- There are added risks in terms of machines malfunctioning (granted very uncommon) – these can be a concern for workshop safety and their costs.
- They will often require a large amount of space to be installed and used properly – space is expensive!
- Replacing a workforce with machines can lead to growing levels of unemployment

Knowledge Organizer – WJEC Eng. – Joining Techniques:

Temporary Joining Techniques:

Nuts and bolts – screw together to make a strong and long lasting removable joint. The compression between the nut and bolt can be better distributed with the help of washers.

Hex bolts, Eye bolts and carriage bolts, or hex nuts, wing nuts, nylon insert locking nuts and cap nuts are examples.

Fixings, Hinges and latches, etc. - These are used to join parts which need to move or frequently disconnect from each other, making it easy to do so, and taking the wear caused by movement over time away from the parts to be joined.

Car door hinges and locks are a good example of this.

Screws - Screws differ from nuts and bolts, as the threads are used to grab into the material itself and pull inward to trap another against the material it is directly tied to.

Self-tapping screws and machine screws are good examples of this.

Cut Joinery - This is mainly used to join woods but can often be used as a method to mechanically join metal parts too, either *permanently or temporarily* by cutting parts to interlock accurately with one another.

Dovetail, halving, mortice and tenon or mitre joints, and morse-tapers are good examples of this technique.

- When choosing how we will join materials together, we need to think about the purpose of the joint, the properties of the materials being joined, what conditions it will be exposed to, and whether the parts will need to be taken apart during the product's lifetime.
- If it will need to be taken apart again, we will need **temporary joining techniques**, if it should stay together indefinitely, then a **permanent joining technique** might be a better choice.

Permanent Joining Techniques:

Fusion Joining – This involves melting parts together, fusing the material in each and making a very strong joint as the materials become bonded at an atomic level as a result of intense heat, usually with the help of a filler metal.

MIG welding, TIG welding, resistance welding, brazing and soldering are all examples, sourcing their heat from electricity or a flame.

Rivets – This joining technique involves feeding a rod (usually metal) through holes in the parts to be joined, and forcing it to become splayed at each end, permanently trapping the material between its splayed ends and making a strong joint.

Blind (Pop) rivets, and round head or counter-sunk solid rivets are good examples.

Adhesives – more commonly called glues, these use a third material spread between materials to chemically bond them together as the glue adheres to both and sets to both.

PVA, Polyurethane, contact glues, and resins like epoxy give a good permanent bond while others like hide glue can provide a strong bond which can easily be undone by heating them to soften the glue again (like how you can heat the glue on a phone to replace the screen).

Folding & Crimping – This technique involves bending and compressing or stamping parts to lock against one another, but it requires the material to be malleable, so it is mainly performed on metals which can be deformed without breaking and have the strength to resist unravelling.

Crimp connectors for wires or the folded joint on a food tin/drink can are good examples.

Knowledge Organizer – BTEC Eng. Unit 1 – Welding:

- Welding is a permanent joining technique
- It is mainly done on metals and thermoplastics (which have the ability to be remelted after initially being set in place)
- The process involves melting both parts (base materials) together, in order to make a very strong joint.
- Usually when welding, another material will be added to the joint in molten form, which helps bond to both base materials, and strengthening the joint once it has set.
- There are a number of different types of welding process including:
 - ❖ Oxy Acetylene Welding
 - ❖ Electric arc welding
 - MIG Welding
 - TIG Welding
 - ❖ Spot & seam Welding
- **Brazing** and **soldering** are similar processes, but the exception is that the base materials do not get melted and they are bonded solely by the third party molten material setting between the base materials and bonding to each.



Safety Issues:

- ✓ The extreme brightness of the arc can burn the retinas in your eyes, so eye and face shields must be worn
- ✓ The fumes from the welding process can be dangerous and can sometimes starve the area of oxygen
- ✓ Platters and sparks from the welding process can cause burns and blisters, so leather gloves should be worn

Electric Arc Welding:

This generates sufficient heat to melt the joint edges by creating an electric current through a gap (arc) between the materials being joined and the filler rod (electrode). The Arc at the gap is caused by high electrical current bridging the distance between the electrode and the material you're working on, causing high temperatures at that point. The electrode is coated in a flux which, when melted, prevents the joint area becoming oxidised.

MIG (Metal Inert Gas) and **TIG** (Tungsten Inert Gas) welding use a *gas jet* around the filler wire to prevent oxidation of the material. Different gases are used with different materials, e.g. Argon is used with aluminium.

As you create the weld joint, the filler wire is melted into the seam, and will eventually need replacing once it runs out.

MIG Welding

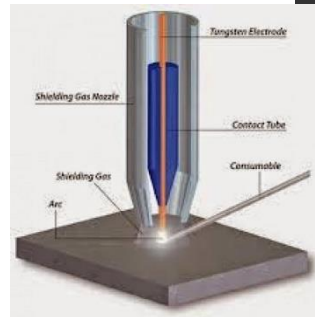
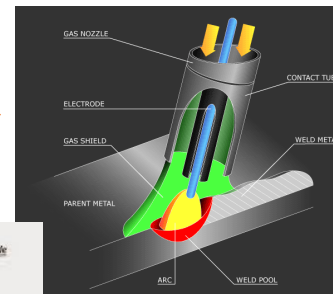

TIG Welding

Oxy-Acetylene Welding:

This uses a mixture of oxygen and acetylene gas to create a flame that will burn at a temperature of around 2500 degrees Celsius at the hottest point. This will clearly be sufficient to melt mild steel at the joint allowing the melting of a filler rod to fuse the joint edges together.

Because of the highly flammable nature of the acetylene gas, this type of welding is considered more dangerous.

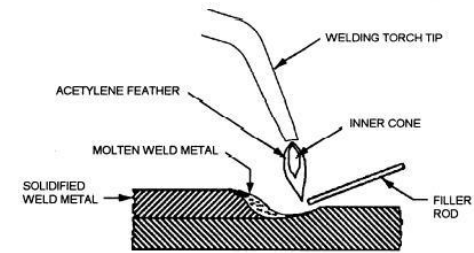

Resistance Welding:

Both spot and seam welding use an electric current as the heat source.

Spot welding as the name suggests **provides a spot of heat** to fuse the metals together. It is usual to find a series of spot welds in a structure like a **car body shell**.

Seam welding, on the other hand, passes an electric current through the material as it passes under the rollers. A typical application for this type of joining method is **tin coated mild steel food and drinks cans**.

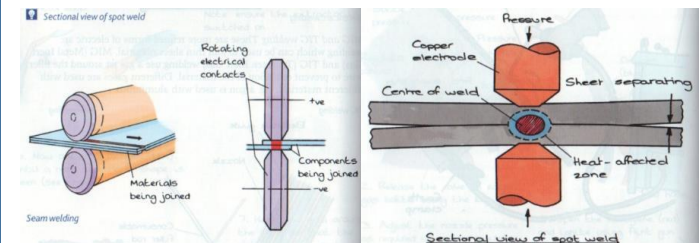

Knowledge Organizer - Engineering - Design Specs:

Examples of Important Design Specifications:

Design specs like those listed below are important because **they guide the design process**, so we know if we are *making the correct decisions*. They can help provide a target, *outlining something we need to include*, or show restrictions, *and things we need to avoid*.

Form – relates to the shape and size of a product's design, like the scale of it, or why it is shaped the way it is – eg: airplane wings

Function – focusses on the purpose of the design, and what it will need to be able to do, and whether there will be multiple functions to balance

User Requirements – Considers who the intended user will be, and what they will want from the product in use – this will be helped a lot by surveys or customer feedback, and by customer profiling so you know the intended user and what they want.

Ergonomics – relates to designing products to fit well with the human body so the result is easy or comfortable to use, depending on the user.

Cost – looks at how expensive it will be to produce; this can be a big challenge in design/production, to aim to get the best result on a budget. How much will it cost for materials? To make? What profit can be made?

Material requirements – deciding what materials will be used to make the product and why? eg: *aesthetics*, properties, production options, etc.

Sustainability – considers the potential environmental impact of the product due to materials, energy used, the lifespan and end of life options for the product, can it be recycled, etc. This is increasingly important!

Designs are developed over time to improve on the solutions we have.

Sometimes, it can be useful to come up with creative solutions to a problem then adjust the idea to solve for required specs by developing the idea.

Design Development:

- Some development is driven by demand, where some products need to change over time so they don't go out of date – eg: computers
 - Other designs don't need to be changed – eg: a fork
- Some reasons designs get developed over time:
- Feedback from customers
 - Change in demands for the product
 - Bug fixing – solving flaws in old design
 - New technologies, making improved solutions viable.

- Design specifications are the **specified requirements for a design solution to have**.
- They are vital in guiding the design process, so that what we design is meeting the needs of the function, performance, the user, the materials, or legal requirements for example
- Without design specs. the design process would be aimless, and the result will likely be flawed and ineffective, or unpopular, because it does not provide a good solution to a problem

Scale of Production:

- **One-off production** means we are designing to produce *a single product* – it will be bespoke/custom made, and will often be expensive
- **Batch production** – *making products/parts in batches* to help control costs and produce more parts faster
- **Mass Production** – *making thousands* of the product, using automated production to make it more affordable
- **Continuous production** – making an unspecified amount of the product, where the same thing is always in demand and always made the exact same, like pens.

The **scale of production** will have a big impact on a design, as it will impact design aspects like:

- **Manufacturing options**
- **Standardised part design** between products
- The setup/running **costs**
- The **demand** for the product
- **Time** needed to produce
- How **sustainable** it will be.



Impact of Technology:

- ✓ New material options, allowing for improved strength, or more compact design, improved performance, etc.
- ✓ New manufacturing options, like CNC machines, automatic production like injection moulding, etc. allowing for faster production
- ✓ CAD – allowing for faster design with increased accuracy and more clear communication. Also allows performance simulation of parts
- ✓ Better communication, between designers & manufacturers, but also more targeted advertising, and more opportunity for feedback & performance
- ✓ Change in demand for a product's performance – improved/more diverse functionality – think about the phones shown for example.
- ✓ Rapid prototyping much easier, making it more feasible to make a “mock-up” of a design to test its effectiveness

- Sustainability is an approach to living, and operating a business with the aim of preserving resources, and in doing so, aiming to minimise harm to the planet. It can help us to:
 - Reduce our reliance on non-renewable resources, like fossil fuels which will eventually run out
 - Reduce the amount of carbon dioxide and other harmful chemicals being released into the atmosphere; thus reducing our impact on global warming
 - Help us reduce the amount of waste being produced
 - Help reduce costs associated with operating wastefully in business or in daily life.
 - Improve public image of a company as buyers become more environmentally conscious.

The Four R's of Sustainability:

- **Reduce:**
 - Aims to reduce the amount of impact we have on the environment by reducing waste/energy used/reliance on harmful materials or chemicals/needless packaging or transport.
- **Reuse:**
 - Reusing materials and resources where possible to break the cycle of our “throw-away culture” meaning no energy is wasted in producing replacements for reusable or repairable parts, and eliminating some of the energy consumption associated with recycling
- **Recycle:**
 - Harvesting materials from used products which can be effective raw materials for new products – this reduces demand for newly sourced raw materials which is particularly important in the case of non-renewable materials like plastics which come from oil.
- **Recover:**
 - Harnessing energy from waste which cannot be reused – done by means of incineration at extremely high temperatures, producing electricity.

Green Energy Sources:

Wind Energy:

Uses Wind turbines to generate electricity – work well on high ground and coastal areas.

- ☺ Produce no pollution once up and running
- ☺ Can produce impressive amounts of power
- ☺ Use little land space.
- ☹ Reliant on weather conditions
- ☹ Can be noisy, particularly if there are many
- ☹ Many people argue that they are ugly and intrusive in areas of natural beauty

Hydro Energy:

Harnessing energy from the movement of water; whether that be a dam in a river, waves or tidal motion.

- ☺ Dams can be shut down to reduce running costs if power demand is low
- ☺ Minimal pollution produced.
- ☺ Can produce energy for decades once built and set up.
- ☹ Ideal locations can be difficult to find for dams
- ☹ High setup and maintenance costs
- ☹ Tidal energy has not been very efficient so far.
- ☹ Some dams cause local flooding

Solar Energy:

Harnessing energy from the sun's radiation. Photovoltaic Cells will produce electricity in this way. Solar water heaters will heat water using a different type of panel.

- ☺ Becoming increasingly efficient through research
- ☺ Solar farms can harvest a lot of power, or panels can be installed on individual homes
- ☺ Do not need intense sunlight to work
- ☹ Can be expensive to buy and install
- ☹ Need to be kept very clean to work most efficiently

Geothermal Energy:

Harnessing naturally occurring heat from the earth's crust to warm homes or generate electricity (at larger scales) using compression and decompression of liquid in pipes using a “heat pump”

- ☺ Renewable and reliable source of energy – the crust of the earth will always be warm
- ☺ Can save a lot of money once set up and requires little maintenance
- ☹ Can involve large initial investment costs to setup – deep drilling
- ☹ It does use some electricity to run
- ☹ Ideal locations for large scale production are hard to find

Knowledge Organizer – Engineering Metals



All metals have a *negative environmental impact* because of the energy used in mining and refining the raw materials, but they are very recyclable, and this uses a lot less energy, *making recycled metals a lot more sustainable to use.*

Ferrous Metals:

These are often called “*ferromagnetic*”

- These metals can have **magnetic properties**
- If you want to know if a metal is ferrous or not, you can try sticking a magnet to it to find out.
- Ferrous metals will usually contain iron – either iron itself or an alloy containing iron.
- Because of this **they will usually rust** when they oxidize and can break down over time, so will need to be protected from this in some way
- High melting point and refined by **smelting** – this uses a lot of energy and is not good for the environment
- They generally have good tensile strength, good malleability and ductility and offer good wear resistance

Examples include:

- **Iron** – in its pure form
- **Mild Steel** – 0.05-0.25% carbon – this is more malleable and affordable. Rusts easily – *Example use = car panels*
- **Stainless steel** – alloyed with carbon and chrome – better corrosion resistance and shiny. *Example use = kitchen cutlery .*
- **High carbon steel** – 0.3-1.7% carbon this is harder and deals with heat and friction better. *Example use = drill bits and engineering tools*
- **Cast iron** – up to 5% carbon, very hard, but brittle – more difficult to work with so is usually cast to shape. Can often have silicon added for better corrosion resistance. *Example use = engine blocks, drain covers*

Non-Ferrous Metals:

- Less common than ferrous, because they require more complex production processes – often a form of **electrolysis**, which uses a lot of electricity

Because of this they are generally more expensive than ferrous metals.

- These metals do not contain iron – you will usually find them on the periodic table as elements
- They do not have magnetic properties
- They will not rust when exposed to moisture – they will still oxidize but in a different way, which changes from metal to metal

Examples include:

- **Aluminium** – a soft metal, very malleable, but poor wear resistance and poor tensile strength. Low melting point. *Example use = airplane panels*
- **Copper** – also soft, very malleable and ductile and very conductive. *Example use = electricity wires*
- **Zinc** – a hard metal but has poor tensile strength, and can be brittle – useful for alloying and galvanizing. *Mainly used for purposes noted above*
- **Tungsten** – extremely hard and tough, excellent heat and wear resistance. Highest melting point of any metal, but difficult to work with. *Example use = high performance cutting tools as tungsten carbide, or in lightbulb filament*
- **Titanium** – highest strength to weight ratio of any metal – quite expensive, but good strength

Alloys:

Alloys are combined materials

- They are metals which are made up of 2 or more elements – these may be 2 metals or a metal and another element, like how steel = iron + carbon
- Because they are combined materials, you won't find these on the periodic table
- They are usually made to combine the better qualities of each to make a new material which will perform well for particular jobs
- The input materials used, and the ratio of the mixture will determine the properties of the alloy – we have seen this where different levels of carbon will give different types of steels.

Examples include:

Brass - copper & zinc mix (about 60:30) – yellowish gold, very malleable and ductile, not very hard, low melting point so good for casting.

Example use = trumpets, a filler metal for brazing

Bronze – copper & tin mix (about 88:12) – more brown in colour than brass, one of the first known alloys, quite malleable and ductile, hard and conductive – *Example use: drum cymbals, springs and bearings*

Nitinol – a “*smart alloy*” or *shape memory alloy* – it is a mixture of nickel & titanium (about 50:50) it has excellent fatigue resistance is super-elastic, and can if bent out of shape then heated, it will return to its original shape. *Example uses: stints used in heart surgery, heat controlled switches*

Knowledge Organizer – WJEC Eng.

Unit 1 – Polymers

- Polymers (plastics) can be manmade *or* naturally occurring like some rubbers, harvested from plants.
- They don't break down over time, which gives them a good lifespan but makes them difficult to dispose.
- However, most are manmade, using the **polymerization** process, which converts fossil fuels like crude oil and gas into polymers, which are chains of molecules called monomers fused together
- The result is a range of materials with different properties which are **affordable** and **very easy to manufacture** with making them a very popular material to use in mass production.

Thermoplastics:

- The process of curing (solidifying) a thermoplastic is reversible
- This means that we can take a thermoplastic and soften or melt it with heat, then let it set in a new shape
- These are **recyclable**, as this process is repeatable, but the quality of the plastic can deteriorate the more this is repeated
- They will usually offer advantages like having high strength, good impact resistance, and good hardness, all depending on the plastic you are considering

Examples:

Acrylic:

- Low melting point, easy to reshape with heat, very recyclable
- Can be brittle when cool
- Cheap to buy, comes in many colours and can be transparent, and it is easy to work with

High Impact Polystyrene (HIPS):

- Low melting point, so often used in vacuum forming as thin sheets to make things like yoghurt pots, etc.
- Soft and flexible, good impact strength
- Like acrylic it is widely available, cheap to buy and comes in many colours

High Density Poly-Ethylene (HDPE):

- Easy to melt and recycle
- Flexible and durable – good toughness and resists many chemicals well
- Popular in manufacturing as it can be easily extruded, blow moulded or injection moulded

Thermosetting Plastics:

- These plastics contain polymer chains which link together during the curing process.
- This means that once they set, the process is very difficult, or impossible to reverse without damaging the plastic –they are **not recyclable**
- Because of this they can't be re-softened or melted with heat, which can make them a good option to use where we may have heat
- They offer an advantage of being often in resin form so can be “painted” around a mould to set

Examples:

Epoxy:

- Starts as a resin which cures (hardens) by a chemical reaction when mixed with a catalyst
- Often used as a strong adhesive, or in composite materials like **Carbon Fibre Reinforced Plastic**

- Good strength, rigidity & chemical resistance,

Polyester Resin:

- Similar to epoxy as it starts as a liquid resin before curing into shape
- Good heat resistance and great impact strength, deals very well with moisture - used in boats
- Also used in composites such as **G.R.P.**

Urea Formaldehyde:

- Cures into a hard plastic with good tensile strength and heat resistance
- Often used as an adhesive such as making composite wooden boards like MDF & Plywood
- Can be aerated when curing to make a foam for uses like shock absorbing or insulation

Elastomers:

- Different to plastics in that their chemical bonds are less rigid or structured in coils which lets the material be stretched, bent or compressed easily, with the ability to return to its original shape (**elasticity**) like an elastic band - this is how they get their name
- Some can occur naturally, like the latex which gets harvested from the “rubber tree”

Example: Rubber:

- Great flexibility & Elasticity, can be natural or synthetic – synthetic rubber will have better wear resistance, friction & grip, good for tyres
- Excellent electrical insulator & good heat resistance

Sustainability Issues:

- Since most plastics come from fossil fuels, they are not sustainably sourced since these are non-renewable resources.
- Sourcing plastics from plant oils (called bioplastics) is becoming more popular
- Plastics will not decompose if left in landfill. This causes a lot of waste plastic pollution, so it is vital that they are recycled as much as possible.
- The sourcing of fossil fuels and the polymerisation process both cause a lot of pollution too, so can be harmful to the planet.

Knowledge Organizer – BTEC Eng.

Unit 1 – Modern Composites:

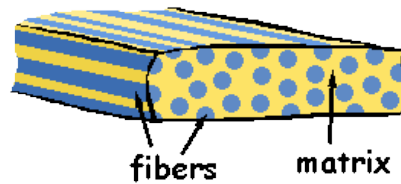

- Modern composites are material combinations which allow us to gain superior performance by combining the properties of 2 materials. Usually one material is suspended in a matrix of the second material (similar to how paper get soaked in PVA glue and sets in shape when making paper mâché).

GRP – Glass Reinforced Plastic:

Often referred to as *fibreglass*, this material is a composite of glass fibres (usually woven into a fabric) which are suspended in a polyester resin.

The glass fibres add a lot of strength to the shape once the resin sets.

The resin gives the composite its rigidity and allows the material to be set into various shapes.



Figure 1: Examples of glass fibre fabrics

- **Properties:**
 - ✓ High strength to weight ratio and very durable
 - ✓ Quite light weight
 - ✓ Relatively affordable
 - ✓ Good chemical and heat resistance.
 - ✓ Good electrical insulator
 - ✓ Low maintenance; no rusting, painting or rotting to worry about.
- **Uses:**
 - ✓ Boat hulls, water slides, etc.
 - ✓ Car body shells, bumpers, etc.
 - ✓ Circuit boards (see PCB manufacture)

Carbon Fibre:

Carbon strands are woven into a fabric which gets suspended and set in a matrix of epoxy resin.

It has the highest strength-to-weight ratio of all construction materials, but is quite expensive.

The fibres add great strength, while the resin allow it to be set into interesting, complex shapes.



Figure 2: Carbon fibre wheel struts on an F1 car

- **Properties:**
 - ✓ Very high strength to weight ratio; very lightweight material
 - ✓ Good chemical and heat resistance
 - ✓ Does not expand much when heated
 - ✓ Electrically conductive
 - ✓ Good resistance to creep or fatigue under prolonged stress
 - ✓ Waterproof
- **Uses:**
 - ✓ High performance cars and boats.
 - ✓ Aircraft frameworks (e.g. in fighter jets)
 - ✓ Bikes and some sports equipment

Kevlar (Aramid Fibre):

Kevlar starts as a liquid that is converted into a fibre (called aramid fibres) and then woven into a very strong, flexible textile material.

This material can be used as a very strong fabric, or can be combined with other materials like resins to make a rigid composite that is light weight but 20 times as strong as steel.



- **Properties:**
 - ✓ Good heat resistance; it will not melt but will begin to decompose over c.450 degrees
 - ✓ Very high *tensile* and *impact* strengths as well as resistance to *torsion* forces
 - ✓ Very high strength to weight ratio and very light weight
 - ✓ Non-flammable, and can be waterproof.
 - ✓ Very difficult to pierce
- **Uses:**
 - ✓ Bullet proof/blast vests
 - ✓ Fuel “tanks” (bags) and bodywork in F1 cars
 - ✓ Fire resistant/ cut resistant clothing
 - ✓ Puncture resistant tyres on vehicles/bikes.

Knowledge Organizer – BTEC Eng. Unit 1 – Tooling Materials:

Diamond:

The hardest material known to man, diamond offers a lot of desirable properties as a tooling material but can be quite expensive. In diamond tools, the material bonding the diamond to the tool will usually fail before the diamond does.

- Exceptional hardness and wear resistance
- Excellent thermal conductivity, but performs very well under very high heat.
- Great chemical resistance, unaffected by acids, alkalis, organic compounds, etc.
- Poor electrical conductor

Uses include: as an abrasive, high performance drills, as a cutting tool in turning or milling for very hard materials

High Speed Steel:

A type of hardened steel which may be alloyed in a number of ways to help improve its performance under stresses like friction and wear.

- High working hardness
- High wear resistance
- Excellent toughness
- Good compressive strength
- High retention of hardness and red hardness (hardness at high temperatures)
- Strength to prevent chips on a cutting edge

Uses include: drills, taps, milling cutters, tool bits, gear cutters, saw blades, planer and jointer blades, router bits, etc.

When thinking about what is suitable as a tooling material, it is important to consider the conditions it will be exposed to and what properties it will need to cope.

Understanding the properties of a material is key to being able to make good material choices.

For example; a hammer head needs to be heavy, tough and have good impact resistance, so we use steel – as a dramatic example, the properties of glass would make that material useless for this application.

Most tools in engineering will be exposed to similar conditions like friction causing heat, wear and abrasion for example.

Properties like **hardness** can help a blade retain a good edge which is useful in most situations, but this brings brittleness lowering its impact strength.

Tungsten Carbide:

Used as a high performance cutting material, this is able to work well under extreme heat and friction without deforming or losing its cutting edge, ensuring a clean cut.

- Extremely hard material
- Maintains hardness and strength at very high temperatures
- Surprisingly good impact resistance despite hardness
- Excellent wear resistance – can last 100 times longer than steel

Uses include: high performance turning/milling bits, mining machinery and armour piercing rounds

Cobalt Steel:

These high performance alloys offer great strength, and fatigue resistance, even at high temperatures, so are often used in jet parts, pumps and valves though they can be expensive and tough to machine.

- High melting point and high “*red hardness*”.
- Very hard but can be brittle
- Wear resistant
- Excellent corrosion resistance
- Great magnetic properties

Uses include: high performance drill and milling bits, turning tools and tapping/die cutting inserts as well as for turbine parts due to their resistance to creep.

Cubic Boron Nitride:

This high performance material is the second hardest material known to man. This means it can keep a sharp cutting edge with a lot of use and under a lot of heat and friction. It is usually used sparingly in the tip of a cutting bit, held by tungsten.

- Maintains hardness very well at high temperatures
- Excellent wear resistance
- Good chemical resistance
- Conducts heat well, but resists deformation under this stress.

Uses include: cutting bits for very tough materials like super-alloys, high performance abrasives, as a coating on surfaces prone to wear.

Knowledge Organizer – WJEC Engineering

- Electronics -

Electrical components

- 💡 **Wires** – made of an electrically conductive material, usually copper, because electrons can flow easily through it, and it is ductile so it can be drawn into fine threads easily; thicker wires can carry more current.
- 💡 **Resistors** – these slow down the current in the circuit, to control the flow of electricity through the circuit
- 💡 **Potentiometers** – also called variable resistors, they can be adjusted to change the amount of resistance in the circuit using a slider or a dial, like a dimmer switch for lights or the volume dial on a radio
- 💡 **Switches** – different switches work in different ways, but all of them work around the principle of breaking the circuit so that electrons can't flow, until the circuit is completed again
- 💡 **Bulbs** – when the current passes through the filament, it gets so hot that it glows with a bright light
- 💡 **LED's** – Light Emitting Diodes, these involve the electrons passing through semi-conductors to create light through a process called electroluminescence.
- 💡 **Power cells:** This is essentially the term for a battery. They provide direct current to the circuit.
- 💡 **Buzzers** – these are components which have a piezoelectric layer which will vibrate when an electrical current is added, creating a basic buzzing noise
- 💡 **Capacitors** – A capacitor is an electrical component which will allow electrons to flow one way through it and store up electric charge. When the capacitor is full, it can discharge the electricity back in the opposite direction. Capacitance is measured in *farads*.
- 💡 **Motors** – These are motion output devices, which spin as a result of the electromagnetic force of the electrons flowing through copper coils pushing against the magnetic field of magnets mounted on the motor's spindle.

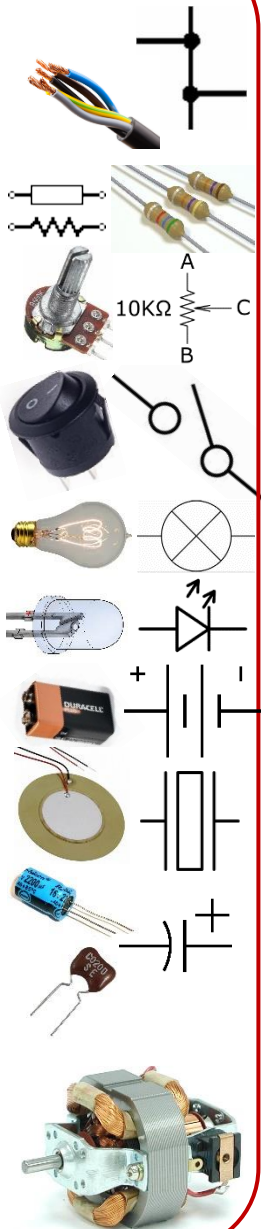

Electricity is the flow of electrons through an electrically conductive material.

Some materials are better at conducting electricity than others. This depends on how freely the electrons in the atoms of the material can move around – in metals for example, the electrons are generally free to move around, so they conduct electricity well.

Key terms:

- 💡 **Voltage** – The measure of electromotive force which shows how much “pressure” is driving the electrons through the circuit.
- 💡 **Amps** – The unit of measurement of the current in the circuit also called amperes – 1 amp = 1 coulomb per second.
- 💡 **Ohms** – The unit of measurement of resistance in a circuit which will slow down and control the current flow.
- 💡 **Ohm's Law** – This important law shows how current (I), Volts (V) and resistance (R) are linked in electrical supply
- 💡 **Fuse** – a component which is used for safety in an electrical circuit – if too much current passes through the fuse, its filament will melt and break the circuit.

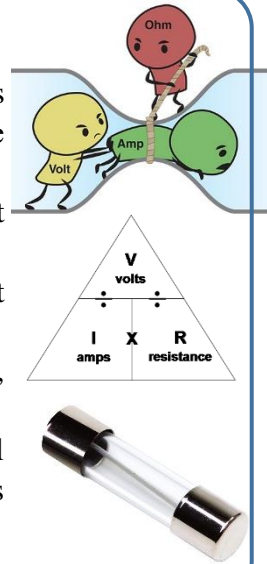

Electrical supply:

Direct Current (DC): when the supply of electricity drives the flow of electrons in one direction only with a constant flow. *Batteries provide direct current.*

Alternating Current (AC): the direction of flow of the electrons alternates, so it is constantly changing direction, at a high frequency (Hz) – for example if the frequency is 60Hz, then it changes direction 60 times per second. *Power sockets provide AC*

Sourcing electricity:

Most electricity is made in a generator, where *magnets are spun quickly on a rotor, and their magnetic field causes electrons to flow in large coils of copper in a part called a stator.* It works the same as a motor, so a motor can also be used to generate electricity. The force to spin the rotor may come from different sources like: high pressure steam from **burning fossil fuels** (the most common source), the spinning blades on a **wind turbine** or spun by water flow in a dam, or by using the spinning of the engine in a hybrid car. Other sources of electricity include **solar power**, or **electrochemistry**, where a chemical reaction will generate an electric charge.

Knowledge Organizer – WJEC – Engineering Maths:

Maths is a vital aspect of engineering, no matter what field you are working in.

Every **exam paper will have maths questions** included somewhere in the exam.

Past papers have mainly included questions which ask you to calculate the area or volume of shapes or products.

The **area is the amount of 2D space that a shape will take up** and will be calculated differently depending on the type of shape.

The **volume of an object is the amount of 3D space an object will take up** and will be calculated by finding the area of a face of the object, then multiplying this by the depth or height of the object.

- Many of these questions will involve calculating the area or volume of more complex shapes which involve *breaking up the shape to calculate the area/volume of each section separately*, then adding up the results, or subtracting parts which are void spaces.
- Some worked examples of this are included to the right.

Squares, Rectangles and Cuboids:

The area of a square or rectangle is found by multiplying the length of the base by the height. To then find the volume of a 3d cuboid, we must multiply this area by the depth

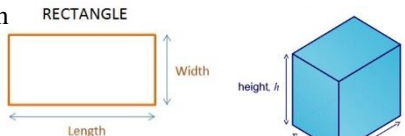

The area of the base = length × width

So,

Volume of a cuboid = length × width × height = lwh

Area of rectangle = Length X Width

Circles & cylinders:

The area of a circle is found using the equation $A = \pi r^2$ – where π (pi) = 3.14 and r = the radius of the circle. Then to find the volume of a cylinder, we multiply the area of the circle by the length of the cylinder:

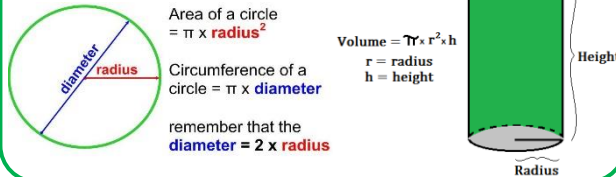

Triangles & triangular prisms:

The area of a triangle can be calculated by the **(base x height) ÷ 2** This makes sense if you consider a triangle as half of a rectangle – it is the same equation but halved. As before, the volume of a triangular prism is found by the **area of the triangle x the length of the prism**

Volume of triangular prism = area of cross-section × length

$$= \frac{1}{2} \times b \times h \times l$$

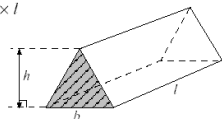

Other common shapes we can calculate the area/volume of:

Parallelogram:

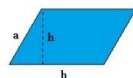

area = base × height

Area of a Trapezoid

$$A = \frac{1}{2}(a+b)h$$

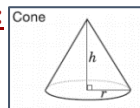

$$V = \frac{(\text{area of base})(\text{height})}{3}$$

$$V = \frac{1}{3} \pi r^2 h \quad \text{or} \quad V = \frac{\pi r^2 h}{3}$$

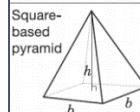

$$V = \frac{(\text{area of base})(\text{height})}{3}$$

$$V = \frac{1}{3} b^2 h \quad \text{or} \quad V = \frac{b^2 h}{3}$$

$$\text{sphere} = \left(\frac{4}{3}\right) \pi r^3$$



Other key geometry terms and equations:

- **Radius:** the radius is the distance from the centre of a circle to the outside edge
- **Diameter:** this is the overall width of a circle from one side to the other, measured through the centre point, so it is twice the radius; $d = 2r$
- **Perimeter:** this is the length of the outside edge of a shape – there is a different equation based on the shape
- **Circumference:** this is the name given to the length of the perimeter of a circle, found by $\pi \times \text{diameter}$ ($\pi = \text{Pi} = 3.14$)
- **Tangent:** this is a point of contact between 2 shapes – if a line touches a circle on one place, it is a tangent line. If it cuts through the circle, then it is a chord, with 2 tangent points
- **Surface area:** this is the area of the surface of a 3D shape, found by adding up the area of each surface
- **Vertex:** Where two lines meet, or the tip of an angle is located, either on a 2D or 3D shape.
- Remember area is your units squared – mm^2 while volume is in your units cubed – mm^3

Worked examples of area and volume questions:

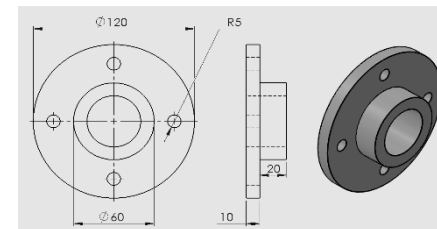

Calculate the volume of material needed to make the metal flange shown. The hole through the centre has a diameter of 40mm

First, we can calculate the volume of each cylinder, then add them:

- $V = (\pi r^2)(h)$ for each section:
 $\diamond (60^2)(3.14)(10) + (30^2)(3.14)(20)$
- $V = 113,040 + 28260 = \underline{141,300\text{mm}^3}$

Next, we need to subtract the volume of each of the holes:

- Centre hole = $(20^2)(3.14)(30) = 37680\text{mm}^3$
- 4 outer holes = $[(5^2)(3.14)(10)] \times 4 = [785\text{mm}^3] \times 4 = 3,140\text{mm}^3$

Total material removed = $37,680 + 3,140 = \underline{40,820\text{mm}^3}$

Total volume of material:

$$\text{➤ } 141,300\text{mm}^3 - 40,820\text{mm}^3 = \underline{100,480\text{mm}^3}$$

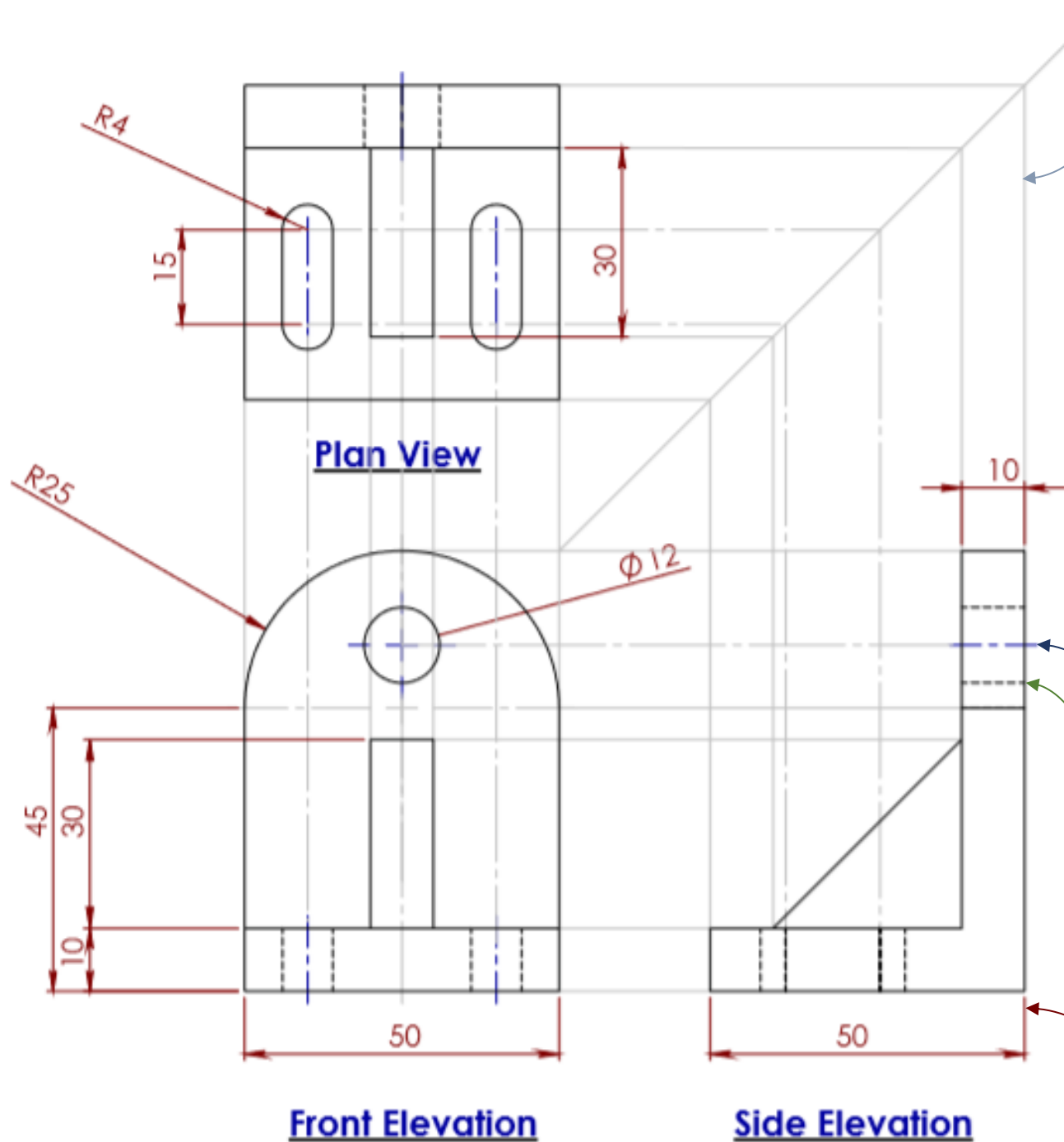

These **construction lines** should be faint, but just visible, to help **link together important information from each view** – we can see how the measurements from our plan view and side elevation can be easily transferred from one view to another by projecting them vertically & horizontally through a 45° line

An **Isometric view** is a **3D projection** of the object being drawn, and it can be very helpful to help visualising the object the object drawn.

- Each horizontal line gets projected back at 30° while vertical lines stay vertical
- We do not add Hidden Detail to isometric views.

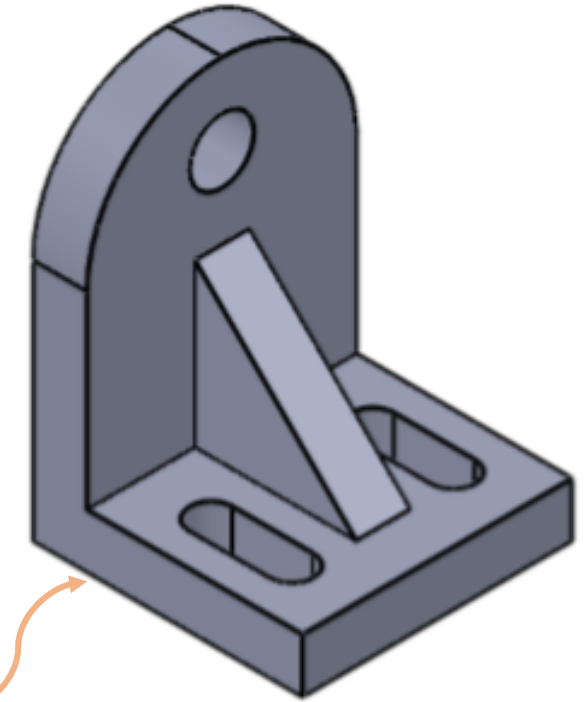

Isometric View

Broken lines drawn with **long-short-long dashes** like this represent **centrelines**, like to find the centre of a circle

Evenly dotted lines like this represent **hidden detail**, showing us important information, which is hidden behind a surface, like the edge of the hole in this case

These red lines represent **dimension lines** to show us **measurements** of the part – but in a normal engineering drawing they would be black, not red, and drawn with a finer line weight so they don't interfere with important drawing lines.

- The measurement shows the distance between the arrows (**headers**) at each end – in this case the measurement shows that the bracket is 50mm deep, measuring the distance left-to-right.
- The line connected to the tip of each arrow is called a **leader**, and it is used to help us trace the dimension line back to the point it is measuring from, since it would be messy and difficult to read if the measurements were too close to or laid over the drawing itself.

- The symbol below is used to help show that the drawing has been laid out in third angle orthographic projection.
- This means that the **Plan view should be directly above the Front Elevation**, while the **side elevation should be drawn directly beside the front elevation** and level with it to show what the object would look like if viewed from that side – for example the side elevation here is to the right hand side of the front elevation and shows what the bracket would look like if viewed from the right side of the front elevation.

Third Angle Orthographic Projection Symbol:

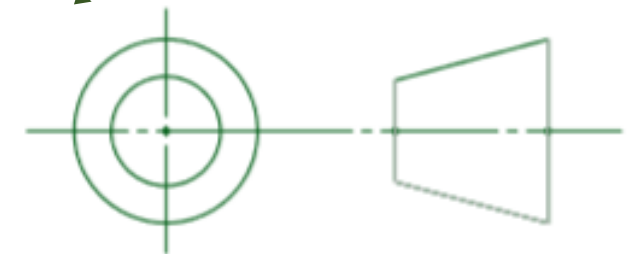

$\phi 12$ The symbol ϕ on this dimension represents **Diameter** – so it is telling us how wide the circle is overall.

$R25$ The letter **R** on this dimension tells us the **Radius** of the curve or circle – the distance from the centre to the outside

An orthographic projection will usually have 3 views laid out as we see above, but some may need more views like an **extra side elevation**, an **auxiliary view** or a **cross sectional view** to show enough information to the reader, while others may fit enough detail into just 2 views

When we see a drawing view with diagonal lines like this, it is a **cross-sectional view**, showing us what we would see if we were to slice open the part at that surface. The diagonal lines here are called **hatching**.

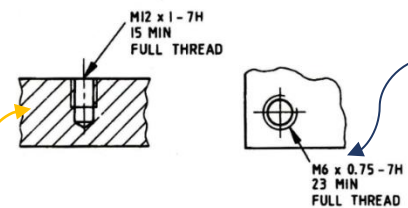

Sometimes a hole will be annotated with an **M** instead, like the **M6 x 0.75** here – this tells us that **the hole is tapped** with screw threads to accept an **M6 bolt** – so it should be drilled with a smaller drill bit (eg. 5.5mm) to allow for the size of the threads.

The **title block** is a very important part of an engineering drawing, as it will provide important information like the material used, the amount of that part needed, the name of the part, or the scale of the drawing compared to real life for example, as shown here.

Part Name: Angle Bracket	
Part No: 1	Material: Mild Steel
Dwg #: 1	Qty: 4
Assembly:	Scale: 1:1